

UNICARRIERS[®]

□ FORKLIFT □



CF30N - CF80N Series

Engine Powered Forklifts

LP and Dual Fuel

3,000 - 8,000 lbs. Capacities | Cushion Tire



CF Series Applications

Powered by our EK21 and EK25 engines, the CF truck series sets the standard for performance, using less fuel and delivering more cycles per hour in a variety of demanding applications that include:

- Manufacturing
- Warehousing
- Recycling
- Beverage/Bottling
- Trucking



Look for these symbols for features available only on UniCarriers forklifts or that provide a proven performance advantage as compared to competitive trucks.



NEVER QUIT.

It defines our forklifts and the company that builds them.

Over the course of a century, the company known as UniCarriers took shape. As we grew and evolved into a US manufacturer with a global reach in nearly 100 countries worldwide, much has changed, but one thing hasn't: our mission. UniCarriers is committed to providing you with the ultimate in reliability, performance, and value.

And that commitment can be seen in the CF Truck Series. Powered by our legendary EK21 and EK25 industrial engines, our rugged CF forklifts deliver greater torque and horsepower, reduce CO, HC and NOx exhaust emissions, and come standard with some of the most advanced performance, security and operator comfort features available anywhere. Plus, it's all backed by the best standard, limited warranty in the business.



Up Your UpTime

Discover reliability features that cut downtime and keep your business up and running



Comfort Zone

Your drivers and your entire operation will benefit from our comfort & productivity features



Power & Performance

You'll find amazing efficiency, reliability and performance in our EK21 and EK25 engines



Sweet Savings

The CF Series is designed to deliver you a low cost of ownership year after year after year



Play It Safe

Safety is everybody's business, and the CF Series is all business when it comes to safety



First-Class Control

You're in complete control when it comes to managing costs and productivity



Make It Yours

Already well appointed, CF Series can be customized to meet your specific needs



To learn more, and a find a dealer near you, visit LogisnextAmericas.com/UniCarriers



Up Your UpTime

When it comes to keeping your operation up and running, the CF truck series offers you significant advantages, beginning with a reliable cooling design, service reminders and longer maintenance intervals. Throughout the CF truck series you'll find innovative and proven protection and warning systems to help you maximize uptime, while minimizing cost.

Longer Preventative Maintenance Intervals

With the CF truck series, most major service intervals are only required every 800 hours, reducing labor and lowering your operating costs.



Trained technicians can **program service interval alerts** for each unit in operation through the display panel. Drivers are notified when scheduled maintenance is required.



The display of the CF series includes **standard warnings**, like an **air cleaner light (if clogging occurs)** and **low coolant level**. You'll find common sense features like these come as standard equipment on our forklifts – but not on our competitors'.



Easy LP Tank Changes

With our simplified LP replacement system, an optional bracket swings out 90°, then pulls down to a manageable height, for faster, easier tank replacement. *Not available on all models.*



Keep your starter and battery healthy with a **starter interlock**. This optional equipment **protects the forklift's starting system** by restricting repeated attempts to start the engine when the LP system is out of fuel.

A standard **parking brake transmission interlock** keeps the forklift in neutral and prevents the operator from driving while the parking brake is engaged to protect the brakes and transmission and reduce premature brake wear.

Inhibit operators from shifting at high speeds with our **SmoothShift** system. This option limits transmission shock and excessive wear — and extends service life too.

Sensor monitors radiator coolant temperature

Sensor monitors transmission oil temperature

Hot Air

Cool Air

Cool Air

Bottom Bypass Design

From water outlet (Bottom bypass)

To water pump

From intake manifold (Bypass)

From radiator

Defend Against Overheating

Our reliable cooling system includes an electronic engine protection and warning system that **monitors radiator fluid and transmission oil temperatures at all times**. This system also contains a field-proven bottom bypass design with thermostat to **prevent hot spots and prolong engine life**. And its large 10-blade fan and aluminum radiator produce effective cross-flow cooling.





Comfort Zone



Excellent Visibility

A standard high-visibility carriage* and your choice of an OptiView®, triple stage or wide-view mast — together these features produce clear sightlines for both loading and moving.

**Available at no additional cost on model capacities up to 5500 lbs.*



Our Seat Supports Your Driver and Your Productivity

The lumbar support and weight adjustments create customized comfort for the operator, while a non-cinching seatbelt allows a wider range of movement. The full suspension design absorbs shocks for a smoother, more comfortable ride — and it's all standard on CF Series forklifts.

Lumbar support adjustment

Weight adjustment

Seat and backrest cushions can be individually replaced for enhanced savings.



Travel Ergonomics

The optional secure assist grip makes it easier to maintain a rear facing position while reversing. A horn button is included.



Convenience at Your Fingertips

Standard automotive-style controls are located on either side of the steering column for accessibility and intuitive operation.

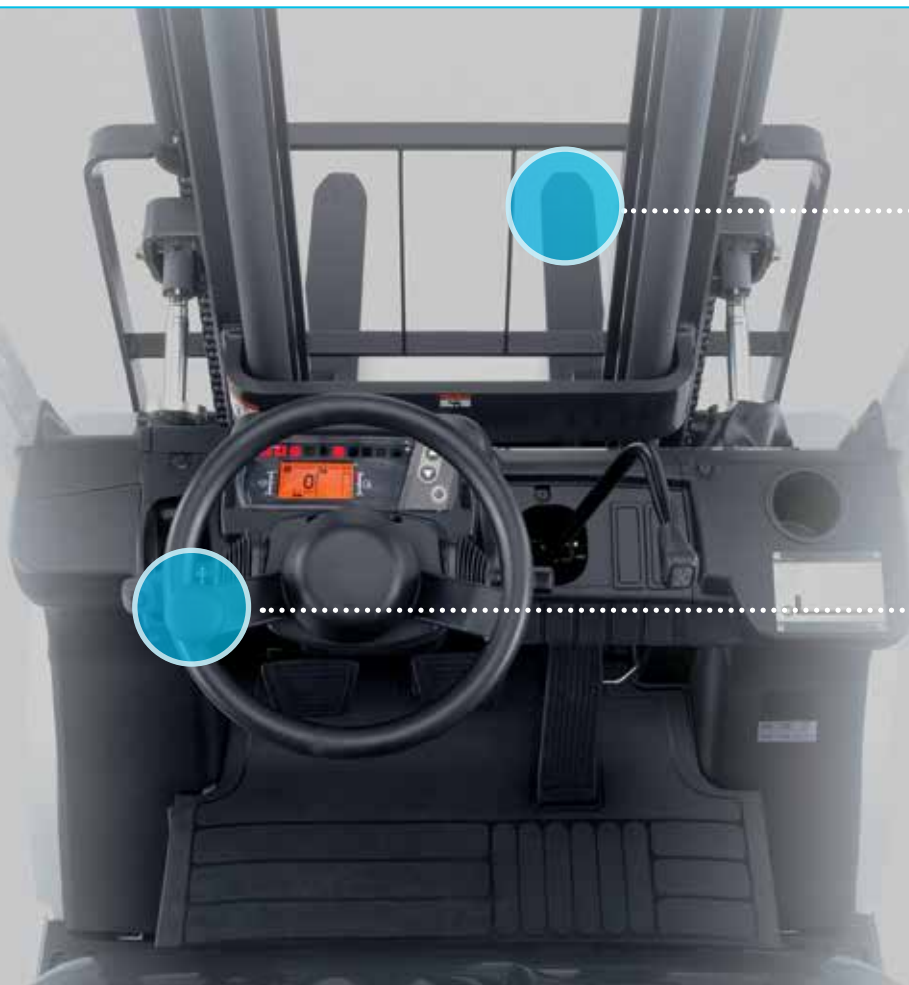

Excellent Fork Tip Visibility

Controls are ergonomically placed across a low profile cowl, making visibility while picking up loads easier for a variety of operator heights.

Add a Spinner Knob for Easier Handling

Operators love this optional feature because it gives them even easier control behind the wheel.



Power & Performance

Operator Efficiency Achieved

Choose the optional integral side shifter resulting in fewer moves to store and retrieve loads, while minimizing capacity loss versus hang-on designs.

More Power, More Efficiently

Advanced engine technology makes it possible for our EK21 and EK25 engines to deliver **greater torque at lower RPMs**. This is achieved due to a combination of factors, including **direct ignition coils connected to each cylinder**, as well as electronic monitoring and control systems. CF models also include an atmospheric sensor that helps maintain exhaust emission performance.



Paired for Maximum Performance

Built to our specifications, the CF transmission is uniquely designed to **optimize the horsepower and torque of our EK21 and EK25 industrial engines**. This proven drivetrain delivers powerful, yet efficient performance.



Sweet Savings

Extra Protection Without Extra Expense



In the event of excessive heat or loss in engine oil pressure, our **Powertrain Protection System** reduces engine RPM for longer engine and drivetrain life. This great feature is standard on models powered by our EK21 and EK25 engines, versus competitive forklifts requiring a costly add-on.



Long Life LEDs

Everything about the CF Series is designed for longer life and greater savings, including the standard LED headlights that deliver greater visibility while being more economical and cost-effective over the life of the machine.

Repositionable Headlights

*Based on typical traveling operation in unloaded condition.
Time interval varies depending upon individual application and usage.



Play It Safe

As a leader in clean air engines for nearly a decade, our products have benefited from the knowledge gained through our automotive heritage. Our EK21 and EK25 industrial engines incorporate an electronic engine control system, using a closed loop design to produce high combustion efficiency with lower and cleaner emission levels. We've also included several security systems as standard, and more options to meet your particular needs.



Additional Features

Several features are available to tailor your forklift for the application and the work environment, including:

- **Seatbelt Interlocks Option** include a variety of choices for restricting forklift operations if the seatbelt is not latched.
- **Fire Extinguisher Option** mounted to the overhead guard pillar, for quick and easy access.
- **Orange Seatbelt** (standard) is highly visible, making seatbelt usage easier to enforce.
- **UL Safety Rating Option** on LP models for hazardous environments.

Operator Presence System



This comprehensive system includes a **seat-actuated power interrupt with mast-lock**, automatically preventing lift and tilt operations if the operator leaves the seat. The **return-to-neutral** feature minimizes forklift movement if the operator leaves the truck while still in gear. Other audible and visual warnings come standard, including **parking brake warning** and **seatbelt alarm**.



A rubber damper provides excellent stability and easier handling

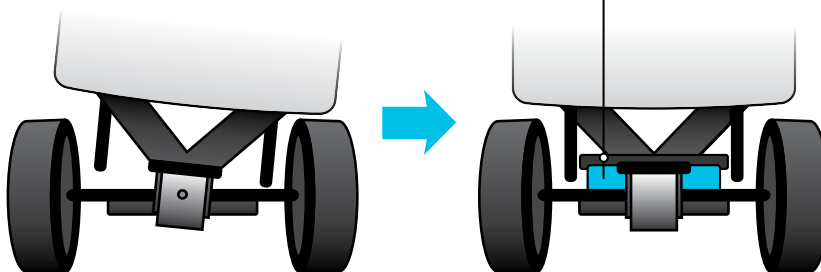

Safety Doesn't Have to be Complicated

Unlike the complex systems offered by some competitors, our cushioned stability control is simple, extremely effective and **low maintenance** — excellent lateral stability is achieved by a rubber damper placed between the axle and frame.



First-Class Control

The Ultimate in Control

The interactive meter panel on the CF Series provides operators and technicians with a wealth of information through its LCD warnings and readouts. A visual indicator for its return-to-neutral feature shows the forklift's transmission direction.



Forward Thinking Back-Up Alarm

Our standard back-up alarm provides plenty of notice to pedestrians and other drivers in the area. For applications with varying noise levels, there is an optional self-adjusting alarm that adjusts sound volume based on ambient noise levels.

Our multi-function display provides an at-a-glance view of critical functions:

- Multipurpose warning
- Check engine warning
- Oil pressure warning
- Charge warning
- Parking brake warning
- Seatbelt warning
- Directional indicator
- Fuel & water temperature gauges
- Multi-function display:
 - Hour meter
 - Clock/calendar
 - Speedometer
 - Programmable service reminder
 - Error codes



Single Handle Control Lever

Our single handle control **combines both lift and tilt functions for greater productivity**. It's standard equipment on the CF Series — and not available from any other forklift brand. Separate control levers are available at no charge.



Auto-Tilt Leveling System

Press the button on the hydraulic control lever to tilt the forks forward to a horizontal position. This option is used for easier load placement and retrieval operations.



Parking Brake Alarm

As part of the Operator Presence System, a warning buzzer alerts the driver if he leaves the seat without first setting the parking brake.



Make It Yours

Choose from a variety of options to customize your ride. If you don't see what you need, contact your authorized UniCarriers dealer for help.



Debris Resistance Package

Includes a belly screen and slotted wheel well inserts to prevent larger debris from entering the engine compartment and affecting key components. For additional protection, select the Recycler Package.



Blue LED Pedestrian Awareness Light

Reverse driving actuates an optional blue spotlight to illuminate the floor, for advanced visual warning.



Tilt Cylinder Protection

Cylinder boots and covers provide extra protection against contaminants that can cause premature wear on cylinder packing.

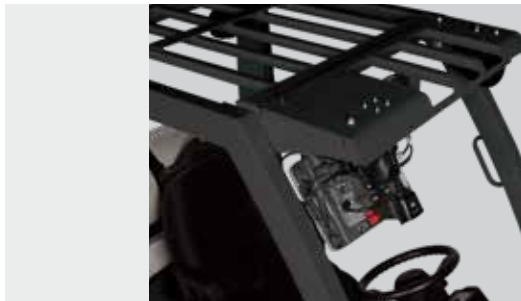

Extended Overhead Guard

Extension provides protection to mounted components, including on-board computer and headlight (shown).



Fingertip Controls

Increase operator productivity with ergonomic hydraulic controls. Choose single joystick or multiple lever designs.



Polycarbonate Overhead Guard Cover

Prevents small debris from entering the operator compartment through the overhead guard.

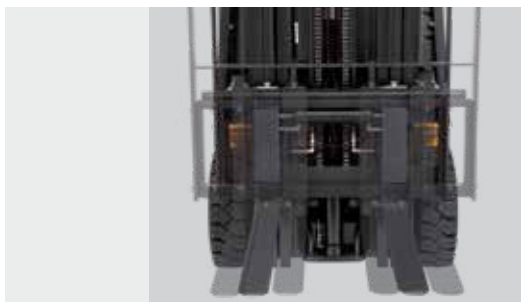

Sidsifting Fork Positioner

Hydraulically positions forks, eliminating the need for manual adjustment by the operator, providing increased productivity.



Rear LED Combination Lights

Package includes a reflector, turn signals, brake and back-up lights. Design provides high visibility and vibration resistance for long life and low service costs. Choose vertical or horizontal mounting (shown).



Radiator Screen

Minimizes debris entering radiator, resulting in more efficient engine cooling.

Option Availability

● Standard ○ Optional

| | LP | DUAL FUEL |
|--|----|-----------|
| VEHICLE MANAGEMENT | | |
| Vehicle Control Module (VCM) | ● | ● |
| Operator security PIN access | ● | ● |
| Interactive LCD meter panel | ● | ● |
| Engine coolant temperature gauge | ● | ● |
| Oil pressure, transmission fluid and low coolant warning lights | ● | ● |
| LPMax low fuel warning | ● | ● |
| SmoothShift system | ○ | ○ |
| Starter interlock - low LP | ○ | ○ |
| POWERTRAIN | | |
| Electronic Engine Control System | ● | ● |
| Engine/transmission protection and warning system | ● | ● |
| Three-way catalytic converter | ● | ● |
| Cushioned stability control | ● | ● |
| Travel speed control (high/low speed selector) | ○ | ○ |
| Controlled acceleration (power/economy selector) | ○ | ○ |
| Diffusion exhaust muffler | ○ | ○ |
| LP SYSTEM | | |
| Swing-out LP bracket* | ● | ● |
| Swing-down LP bracket* | ○ | ○ |
| Fixed LP bracket | ○ | ○ |
| BRAKE | | |
| Parking brake with warning buzzer | ● | ● |
| Parking brake transmission interlock | ● | ● |
| MAST | | |
| Seat actuated auto-mast lock system | ● | ● |
| OptiView® three-stage mast | ○ | ○ |
| High-Visibility Carriage* | ● | ● |
| HYDRAULIC SYSTEM | | |
| Single lift/tilt control lever | ● | ● |
| Separate lift & tilt control levers | ○ | ○ |
| Automatic fork leveling* | ○ | ○ |
| OPERATOR CONVENIENCES | | |
| Fingertip Control | ○ | ○ |
| Single Joystick Control | ○ | ○ |
| Full suspension seat with weight & lumbar adjustment | ● | ● |
| Overhead guard-mounted LED headlights | ● | ● |
| Rearview mirrors | ○ | ○ |
| Rear LED combination light package (turn, stop, back-up) | ○ | ○ |
| Rear LED drive light | ○ | ○ |
| Secure rear grip with horn button | ○ | ○ |
| PROTECTION/SECURITY | | |
| Operator Presence System with return-to-neutral and auto mast lock | ● | ● |
| Seatbelt interlocks | ○ | ○ |
| UL Safety rating* | ○ | - |
| Back-up warning alarm | ● | ● |
| Self-adjusting back up alarm | ○ | ○ |
| Fire Extinguisher | ○ | ○ |
| Parking Brake w/ Warning Buzzer | ○ | ○ |
| Seat Belt Warning System | ● | ● |
| Orange Seatbelt | ● | ● |
| High Visibility Orange Forks | ○ | ○ |
| Blue LED spotlight - front/ rear | ○ | ○ |
| Foundry / Brick Protection Package | ○ | ○ |

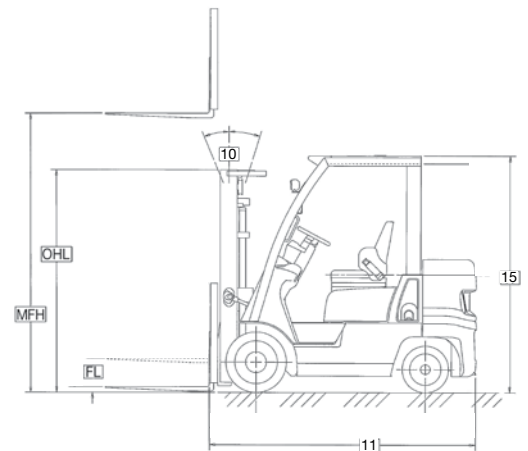
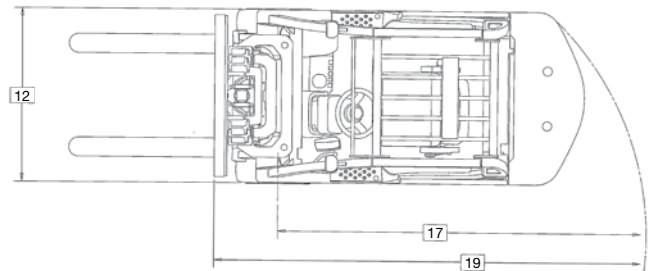

Specifications

| CHARACTERISTICS | Model | | | CF30N | | CF35N | | CFS40N | | CF40N | |
|-----------------|--|--------|------|-------------------|--------------|-------------------|--------------|-------------------|--------------|-------------------|--------------|
| | | lb | kg | | | | | | | | |
| 1 | Capacity – at rated load center | lb | kg | 3,000 | 1,350 | 3,500 | 1,600 | 4,000 | 1,800 | 4,000 | 1,800 |
| 2 | Capacity – at load center-distance | in | mm | 24 | 600 | 24 | 600 | 24 | 600 | 24 | 600 |
| 3 | Power – diesel, gasoline, LP gas, electric | | | LP - G/LP | | LP - G/LP | | LP - G/LP | | LP - G/LP | |
| 4 | Tire type – cushion or pneumatic | | | Cushion | | Cushion | | Cushion | | Cushion | |
| 5 | Wheels (x = driven) – number front / rear | | | 2x / 2 | | 2x / 2 | | 2x / 2 | | 2x / 2 | |
| 7 | Lift with standard two-stage mast – maximum fork height | in | mm | 130 | 3,300 | 130 | 3,300 | 130 | 3,300 | 130 | 3,300 |
| 8 | Lift with standard two-stage mast – free fork height | in | mm | 4 | 100 | 4 | 100 | 4 | 100 | 4.2 | 105 |
| 9 | Forks – thickness x width x length | in | mm | 1.5x4x42 | 40x100x1,070 | 1.5x4x42 | 40x100x1,070 | 1.5x4x42 | 40x100x1,070 | 1.5x4x42 | 40x100x1,070 |
| | Fork spacing – out-to-out minimum / maximum | in | mm | 7.8 / 32.4 | 200 / 823 | 7.8 / 32.4 | 200 / 823 | 7.8 / 32.4 | 200 / 823 | 7.8 / 36.0 | 200 / 920 |
| 10 | Tilt – forward / backward | deg | | 5° / 10° | | 5° / 10° | | 5° / 10° | | 5° / 10° | |
| 11 | Length to fork face | in | mm | 81.9 | 2,080 | 81.9 | 2,080 | 84.4 | 2,145 | 89 | 2,260 |
| 12 | Width – with standard tires | in | mm | 38.2 | 970 | 38.2 | 970 | 38.2 | 970 | 36.2 | 920 |
| 13 | Height – mast lowered | in | mm | 82.9 | 2,105 | 82.9 | 2,105 | 82.9 | 2,105 | 83.1 | 2,110 |
| 14 | Height – seat height | in | mm | 43.3 | 1,100 | 43.3 | 1,100 | 43.3 | 1,100 | 44.3 | 1,125 |
| 15 | Height – top of overhead guard | in | mm | 81.1 | 2,060 | 81.1 | 2,060 | 81.1 | 2,060 | 82.1 | 2,085 |
| 16 | Height – mast extended | in | mm | 179.3 | 4,555 | 179.3 | 4,555 | 179.3 | 4,555 | 179.3 | 4,555 |
| 17 | Minimum outside turning radius | in | mm | 68.3 | 1,735 | 68.3 | 1,735 | 70.9 | 1,800 | 76 | 1,930 |
| 18 | Load moment constant | in | mm | 15.4 | 390 | 15.4 | 390 | 15.4 | 390 | 16.1 | 410 |
| 19 | Minimum aisle - 90° stack - zero clearance w/out load ¹ | in | mm | 83.7 | 2,125 | 84.9 | 2,155 | 84.9 | 2,155 | 92.1 | 2,340 |
| 20 | Travel speed loaded / empty | mph | km/h | 10.9 | 17.5 | 10.9 | 17.5 | 10.9 | 17.5 | 10.6 | 17 |
| 21 | Lift speed loaded / empty | fpm | mm/s | 122/127.9 | 620/650 | 122/127.9 | 620/650 | 122/127.9 | 620/650 | 122/127.9 | 620/650 |
| 22 | Lowering speed loaded / empty | fpm | mm/s | 98.4 | 500 | 98.4 | 500 | 98.4 | 500 | 98.4 | 500 |
| 23 | Drawbar pull – loaded maximum | lb | N | 3,417 | 1,550 | 3,417 | 1,550 | 3,417 | 1,550 | 3,638 | 1,650 |
| 24 | Gradeability – maximum (1.2 mph) loaded / empty | % | | 38 / 20 | | 38 / 18 | | 38 / 16 | | 33 / 21 | |
| 25 | Empty – standard tires | lb | kg | 5,980 | 2,710 | 6,420 | 2,910 | 6,830 | 3,100 | 7,130 | 3,235 |
| 26 | Axle load – with load front / rear | lb | kg | 7,720/1,260 | 3,620/590 | 8,485/1,435 | 3,985/675 | 9,240/1,590 | 4,350/750 | 9,730/1,400 | 4,575/660 |
| | Axle load – without load front / rear | lb | kg | 2,200/3,780 | 995/1,715 | 2,045/4,375 | 925/1,985 | 1,880/4,950 | 855/2,245 | 2,815/4,315 | 1,275/1,960 |
| 27 | Tire size – front, standard | in | | 18x6x12.13 | | 18x6x12.13 | | 18x6x12.13 | | 21x7x15 | |
| 28 | Tire size – rear | in | | 14x5x10 | | 14x5x10 | | 14x5x10 | | 16.25x6x11.25 | |
| 29 | Wheelbase | in | mm | 46.9 | 1,190 | 46.9 | 1,190 | 46.9 | 1,190 | 55.1 | 1,400 |
| 30 | Tread width – front, standard tires | in | mm | 32.3 | 820 | 32.3 | 820 | 32.3 | 820 | 35 | 890 |
| 31 | Tread width – rear, standard tires | in | mm | 32.3 | 820 | 32.3 | 820 | 32.3 | 820 | 35 | 890 |
| 32 | Ground clearance – at lowest point of mast | in | mm | 3.0 | 75 | 3.0 | 75 | 3.0 | 75 | 3.1 | 80 |
| 33 | Ground clearance – at center of wheelbase | in | mm | 4.3 | 110 | 4.3 | 110 | 4.3 | 110 | 4.1 | 105 |
| 34 | Service brakes | type | | drum / foot | | drum / foot | | drum / foot | | drum / foot | |
| 35 | Parking brakes | type | | hand / mechanical | | hand / mechanical | | hand / mechanical | | hand / mechanical | |
| 36 | Engine model | | | EK21 | | EK21 | | EK21 | | EK21 | |
| 37 | Continuous output (S.A.E. gross) | HP | kW | 55 | 41 | 55 | 41 | 55 | 41 | 55 | 41 |
| | | at rpm | | 2,700 | | 2,700 | | 2,700 | | 2,700 | |
| 38 | Maximum torque (S.A.E. gross) | lb-ft | Nm | 111.4 | 151 | 111.4 | 151 | 111.4 | 151 | 111.4 | 151 |
| | | at rpm | | 2,000 | | 2,000 | | 2,000 | | 2,000 | |
| 39 | Cylinder / displacement | cu in | L | 126 | 2,065 | 125 | 2,065 | 125 | 2,065 | 126 | 2,065 |
| 40 | Transmission type | | | automatic | | automatic | | automatic | | automatic | |
| 41 | Number of speeds forward / reverse | | | 1 / 1 | | 1 / 1 | | 1 / 1 | | 1 / 1 | |
| 42 | Battery | volts | | 12 | | 12 | | 12 | | 12 | |
| 43 | Relief pressure – For attachments at auxiliary valve | psi | bar | 1,840 | 127 | 1,840 | 127 | 1,80 | 127 | 1,840 | 127 |

| | CF50N | | CF55N | | CF60N | | CFS60N | | CFS65N | | CF70N | | CF80N | |
|----|-------------------|--------------|-------------------|--------------|-------------------|--------------|-------------------|--------------|-------------------|--------------|-------------------|---------------|-------------------|---------------|
| 1 | 5,000 | 2,250 | 5,500 | 2,500 | 6,000 | 2,700 | 6,000 | 2,700 | 6,500 | 2,900 | 7,000 | 3,150 | 8,000 | 3,650 |
| 2 | 24 | 600 | 24 | 600 | 24 | 600 | 24 | 600 | 24 | 600 | 24 | 600 | 24 | 600 |
| 3 | LP - G/LP | | LP - G/LP | | LP - G/LP | | LP - G/LP | | LP - G/LP | | LP | | LP | |
| 4 | Cushion | | Cushion | | Cushion | | Cushion | | Cushion | | Cushion | | Cushion | |
| 5 | 2x / 2 | | 2x / 2 | | 2x / 2 | | 2x / 2 | | 2x / 2 | | 2x / 2 | | 2x / 2 | |
| 7 | 130 | 3,300 | 130 | 3,300 | 130 | 3,300 | 130 | 3,300 | 122 | 3,100 | 171 | 4,350 | 171 | 4,350 |
| 8 | 4.2 | 105 | 6.7 | 175 | 7.1 | 180 | 7.1 | 180 | 7.1 | 180 | 10.6 | 269 | 10.6 | 269 |
| 9 | 1.5x4x42 | 40x100x1,070 | 1.5x4x42 | 40x100x1,070 | 2x5x42 | 50x125x1,070 | 2x5x42 | 50x125x1,070 | 2x5x42 | 50x125x1,070 | 2x5x42 | 50x125x1,070 | 2x5x42 | 50x125x1,070 |
| | 7.8 / 36.0 | 200 / 920 | 7.8 / 40.2 | 200 / 1,020 | 9.6 / 40.2 | 244 / 1,020 | 9.6 / 40.2 | 244 / 1,020 | 9.6 / 40.2 | 244 / 1,020 | 11.1 / 38.9 | 282 / 987 | 11.1 / 38.9 | 282 / 987 |
| 10 | 5° / 10° | | 5° / 10° | | 5° / 10° | | 5° / 10° | | 5° / 10° | | 5° / 10° | | 5° / 10° | |
| 11 | 91.3 | 2,320 | 93.9 | 2,385 | 95.3 | 2,420 | 96.5 | 2,450 | 96.3 | 2,445 | 98.2 | 2,495 | 100 | 2,540 |
| 12 | 36.2 | 920 | 43.1 | 1,095 | 43.1 | 1,095 | 43.9 | 1,115 | 43.9 | 1,115 | 45.9 | 1,165 | 45.9 | 1,165 |
| 13 | 83.1 | 2,110 | 82.7 | 2,100 | 82.7 | 2,100 | 83.1 | 2,110 | 82.7 | 2,100 | 83.1 | 2,110 | 83.1 | 2,110 |
| 14 | 44.3 | 1,125 | 44.3 | 1,125 | 44.4 | 1,130 | 44.4 | 1,130 | 44.4 | 1,130 | 44.4 | 1,130 | 44.4 | 1,130 |
| 15 | 82.1 | 2,085 | 82.1 | 2,085 | 82.1 | 2,085 | 82.3 | 2,090 | 82.1 | 2,085 | 82.3 | 2,090 | 82.3 | 2,090 |
| 16 | 179.3 | 4,555 | 179.3 | 4,555 | 179.3 | 4,555 | 175 | 4,445 | 178.5 | 4,535 | 178.7 | 4,540 | 178.7 | 4,540 |
| 17 | 78.3 | 1,990 | 82.1 | 2,085 | 82.1 | 2,085 | 82.3 | 2,090 | 82.1 | 2,085 | 82.5 | 2,095 | 83.9 | 2,130 |
| 18 | 16.1 | 410 | 17.3 | 440 | 17.1 | 435 | 17.7 | 450 | 17.9 | 455 | 17.9 | 455 | 17.9 | 455 |
| 19 | 94.4 | 2,400 | 96.8 | 2,460 | 98.4 | 2,500 | 98.0 | 2,490 | 99.2 | 2,520 | 100.4 | 2,550 | 101.8 | 2,585 |
| 20 | 10.6 | 17 | 10.6 | 17 | 10.6 | 17 | 11.5/9.9 | 18.5/16 | 10.6 | 17 | 11.5 / 11.5 | 18.5 / 18.5 | 11.5 / 11.5 | 18.5 / 18.5 |
| 21 | 118.1/127.9 | 600/650 | 94.5/102.4 | 480/520 | 104.3/110.2 | 530/560 | 104.3/110.2 | 530/560 | 88.6/92.5 | 450/470 | 88.6 / 92.5 | 450 / 470 | 88.6 / 92.5 | 450 / 470 |
| 22 | 98.4 | 500 | 98.4 | 500 | 98.4 | 500 | 98.4 | 500 | 82.7/70.9 | 420/360 | 83 / 71 | 420 / 360 | 83 / 71 | 420 / 360 |
| 23 | 3,638 | 1,650 | 3,638 | 1,650 | 4,189 | 1,900 | 3,009 | 1,365 | 4,189 | 1,900 | 6,228 | 2,825 | 6,228 | 2,825 |
| 24 | 28 / 16 | | 27 / 16 | | 28 / 16 | | 44 / 18 | | 24 / 16 | | 38 / 18 | | 34 / 15 | |
| 25 | 7,940 | 3,600 | 8,860 | 4,015 | 9,350 | 4,240 | 9,610 | 4,360 | 9,825 | 4,455 | 10,460 | 4,740 | 11,150 | 5,055 |
| 26 | 11,375/1,565 | 5,360/740 | 12,355/2,005 | 5,820/945 | 13,360/1,990 | 6,300/940 | 13,715/1,895 | 6,465/1,895 | 14,225/2,100 | 6,715/990 | 15,365 / 7,250 | 2,095 / 990 | 16,910 / 7,320 | 2,960 / 1,335 |
| | 2590/5,350 | 1,175/2,425 | 2,705/6,155 | 1,225/2,790 | 2,790/6,560 | 1,265/2,975 | 3,450/6,160 | 1,565/2,795 | 2,755/7,070 | 1,250/3,205 | 3,365 / 1,525 | 7,095 / 3,215 | 3,150 / 1,425 | 8,000 / 3,630 |
| 27 | 21x7x15 | | 21x8x15 | | 21x8x15 | | 22x8x16 | | 21x8x15 | | 22 x 9 x 16 | | 22 x 9 x 16 | |
| 28 | 16.25x6x11.25 | | 16.25x6x11.25 | | 16.25x6x11.25 | | 18x6x12.12 | | 16.25x6x11.25 | | 18 x 6 x 12.12 | | 18 x 6 x 12.12 | |
| 29 | 55.1 | 1,400 | 55.1 | 1,400 | 55.1 | 1,400 | 59.1 | 1,500 | 55.1 | 1,400 | 59.1 | 1,500 | 59.1 | 1,500 |
| 30 | 35 | 890 | 35.8 | 910 | 35.8 | 910 | 35.8 | 910 | 35.8 | 910 | 37 | 940 | 37 | 940 |
| 31 | 35 | 890 | 35 | 890 | 35 | 890 | 36.6 | 930 | 35 | 890 | 36 | 930 | 36 | 930 |
| 32 | 3.1 | 80 | 2.8 | 70 | 2.8 | 70 | 3.1 | 80 | 2.8 | 70 | 3.1 | 80 | 3.1 | 80 |
| 33 | 4.1 | 105 | 3.5 | 90 | 3.5 | 90 | 3.7 | 95 | 3.5 | 90 | 5.7 | 145 | 5.7 | 145 |
| 34 | drum / foot | | drum / foot | | drum / foot | | drum / foot | | drum / foot | | drum / foot | | drum / foot | |
| 35 | hand / mechanical | | hand / mechanical | | hand / mechanical | | hand / mechanical | | hand / mechanical | | hand / mechanical | | hand / mechanical | |
| 36 | EK21 | | EK21 | | EK25 | | EK25 | | EK25 | | EK25 | | EK25 | |
| 37 | 55 | 41 | 55 | 41 | 62.9 | 46.9 | 62.9 | 46.9 | 62.9 | 46.9 | 62.9 | 46.9 | 62.9 | 46.9 |
| | 2,700 | | 2,700 | | 2,700 | | 2,700 | | 2,700 | | 2,700 | | 2,700 | |
| 38 | 111.4 | 151 | 111.4 | 151 | 138.7 | 188 | 138.7 | 188 | 138.7 | 188 | 138.7 | 188 | 138.7 | 188 |
| | 2,000 | | 2,000 | | 1,600 | | 1,600 | | 1,600 | | 1,600 | | 1,600 | |
| 39 | 126 | 2,065 | 126 | 2,065 | 151.8 | 2,488 | 151.8 | 2,488 | 151.8 | 2,488 | 151.8 | 2,488 | 151.8 | 2,488 |
| 40 | automatic | | automatic | | automatic | | automatic | | automatic | | automatic | | automatic | |
| 41 | 1 / 1 | | 1 / 1 | | 1 / 1 | | 1 / 1 | | 1 / 1 | | 2 / 1 | | 2 / 1 | |
| 42 | 12 | | 12 | | 12 | | 12 | | 12 | | 12 | | 12 | |
| 43 | 1,840 | 127 | 1,840 | 127 | 1,840 | 127 | 18,40 | 127 | 1,840 | 127 | 2,625 | 181 | 2,625 | 181 |

Reliability.

It's the defining trait of our company and our forklifts.



UniCarriers' roots extend back over 100 years, and over that time, strong, reliable performance has always been the hallmark of our organization, our people and our equipment.

Today, our unrivaled reliability continues to provide UniCarriers' customers with a competitive edge. And together, we move the merchandise that moves world commerce with greater efficiency, economy and reliability.

When it comes to providing forklifts that make a difference for our customers and theirs...



We Never Quit.

UNICARRIERS[®]
□ **FORKLIFT** □

LogisnextAmericas.com/UniCarriers

SB-CF30-CF80 06-2024 Printed in U.S.A.

© 2024 Mitsubishi Logisnext Americas Inc. UniCarriers is a registered trademark of Mitsubishi Logisnext Co., Ltd. Mitsubishi Logisnext Americas, Inc. reserves the right to make product changes relating to colors, equipment, specifications or available options without notice. For more information, contact your UniCarriers Forklift representative.

