

UNICARRIERS®

□ FORKLIFT □

Platinum II® Nomad® Series



Engine Powered Forklifts

LP & Dual Fuel

3,000 / 3,500 / 5,000 lbs. Capacities | Compact Pneumatic Tire



S P E C I F I C A T I O N S

MAIN TRUCK SPECIFICATIONS

CHARACTERISTICS	1	Manufacturer's Name		UniCarriers	UniCarriers	UniCarriers		
	2	Model	Model designation	AF30	AF35	AF50		
	3	Long Model Code		MAP1F1A15LV / DV	MAP1F1A18LV / DV	MAP1F2A25LV / DV		
CHARACTERISTICS	4	Rated Load Capacity	lb (kg)	3000 (1350)	3500 (1600)	5000 (2250)		
	5	Load Center	Distance	24 (600)	24 (600)	24 (600)		
	6	Power Type		LP - G/LP	LP - G/LP	LP - G/LP		
	7	Operator Orientation		Sit	Sit	Sit		
	DIMENSIONS	8	Tire Type	Front & rear	Pneumatic	Pneumatic	Pneumatic	
		9	Wheels	Number (x=driven) front/rear	2 x / 2	2 x / 2	2 x / 2	
		10	Mast	Maximum fork height	130 (3300)	130 (3300)	130 (3300)	
11			Standard freelif	6.2 (155)	6.2 (155)	4.2 (105)		
12		Forks	Thickness & width	1.5 x 4 (40x100)	1.5 x 4 (40x100)	1.5 x 4 (40x100)		
13			Length	42 (1070)	42 (1070)	42 (1070)		
14		Tilt Angle	Standard mast - fwd/back	5/10	5/10	5/10		
15		Overall Dimensions	Length (to face of forks)	83.9 (2130)	85.0 (2160)	92.9 (2360)		
16			Width (standard tires)	40.7 (1035)	40.7 (1035)	46.3 (1175)		
17			Mast lowered (OHL)	84.3 (2140)	84.3 (2140)	82.8 (2100)		
18			Mast extended with LBR	179.3 (4555)	179.3 (4555)	179.3 (4555)		
19			Height - top of OHG	83 (2110)	82.7 (2100)	82.3 (2090)		
20			Height - top of standard LBR	48 (1220)	48 (1220)	48 (1220)		
21			Width - standard carriage	36.2 (920)	36.2 (920)	36.2 (920)		
22		Grade Clearance	Ramp breakover angle	tan (%)	51	51	39	
23			Departure angle	tan (%)	42	40	40	
24			Approach angle	tan (%)	36	36	25	
25		Turning Radius	Minimum outside	in (mm)	72.6 (1845)	73.8 (1875)	80.7 (2050)	
26		Overhang	Front	in (mm)	15.4 (390)	15.4 (390)	16.1 (410)	
27			Rear	in (mm)	17.7 (450)	18.9 (480)	17.7 (450)	
28		Min Right Angle Stack	Add load length & clearance	in (mm)	88 (2235)	89.2 (2265)	96.8 (2460)	
PERFORMANCE		29	Speeds Maximum	Travel - forward or reverse	mph (kmh)	10.6 (17)	10.6 (17)	10.6 (17)
		30		Lift - full/empty	fpm (mm/sec)	122/127.9 (620/650)	122/127.9 (620/650)	122/127.9 (620/650)
		31		Lowering - full/empty	fpm (mm/sec)	98.4 (500)	98.4 (500)	98.4 (500)
	32	Drawbar Pull Max	Full load	lb (kg)	3748 (1700)	3748 (1700)	3748 (1700)	
	33		Empty	lb (kg)	1984 (900)	1984 (900)	2183 (990)	
	34	Gradeability Max (1.2 mph)	Full/empty	tan (%)	34 / 28	40 / 26	28 / 21	
WEIGHT	35	Truck Weight	Standard truck - no load	lb (kg)	5860 (2660)	6245 (2835)	7910 (3585)	
	36	Weight Distribution	Front axle - empty	lb (kg)	2275 (1030)	2160 (980)	2665 (1210)	
	37		Rear axle - empty	lb (kg)	3585 (1630)	4085 (1855)	5245 (2375)	
	38		Front axle - with rated load	lb (kg)	7600 (3570)	8375 (3940)	10225 (4795)	
	39		Rear axle - with rated load	lb (kg)	1260 (590)	1370 (645)	1685 (790)	
CHASSIS & WHEELS	40	Tire Size	Front - single (or dual) tire		6.00 x 9 Solid	6.00 x 9 Solid	21 x 8 - 9 Solid	
	41		Rear		5.00 x 8 Solid	5.00 x 8 Solid	18 x 7 - 8 Solid	
	42	Wheelbase		in (mm)	50.8 (1290)	50.8 (1290)	59.1 (1500)	
	43	Tread - Center of Tire	Front / rear	in (mm)	34.3/34.8 (870/885)	34.3/34.8 (870/885)	38.4/36.6 (975/930)	
	44	Headroom	SIP to bottom of OHG	in (mm)	42.1 (1070)	42.1 (1070)	42.1 (1070)	
	45	Counterweight Height		in (mm)	46.9 (1190)	46.9 (1190)	42.3 (1075)	
	46	Step Height		in (mm)	18.3 (465)	18.3 (465)	16.1 (410)	
	47	Ground Clearance	Under mast	in (mm)	3.9 (100)	3.9 (100)	2.8 (70)	
	48		Under power unit	in (mm)	3.7 (95)	3.7 (95)	3.7 (95)	
	49		Under frame (WB center)	in (mm)	5.5 (140)	5.5 (140)	5.1 (130)	
	50	Service Brake	Type		Drum and Shoe	Drum and Shoe	Drum and Shoe	
	51	Parking Brake	Type		Hand	Hand	Hand	
	52	Steering	Type		Full Hydraulic	Full Hydraulic	Full Hydraulic	
DRIVE LINE	53	Engine	Model		GK21	GK21	GK21	
	54	Rated Output	SAE gross	hp (kW) @ rpm	55 (41) @ 2700	55 (41) @ 2700	55 (41) @ 2700	
	55	Rated Torque	SAE gross	ft-lb (Nm) @ rpm	111.4 (151) @ 2000	111.4 (151) @ 2000	111.4 (151) @ 2000	
	56	Displacement		cu in (cm ³)	126 (2065)	126 (2065)	126 (2065)	
	57	Transmission	Type		Automatic	Automatic	Automatic	
	58		Number speeds - fwd/rev		1/1	1/1	1/1	

DIMENSIONS

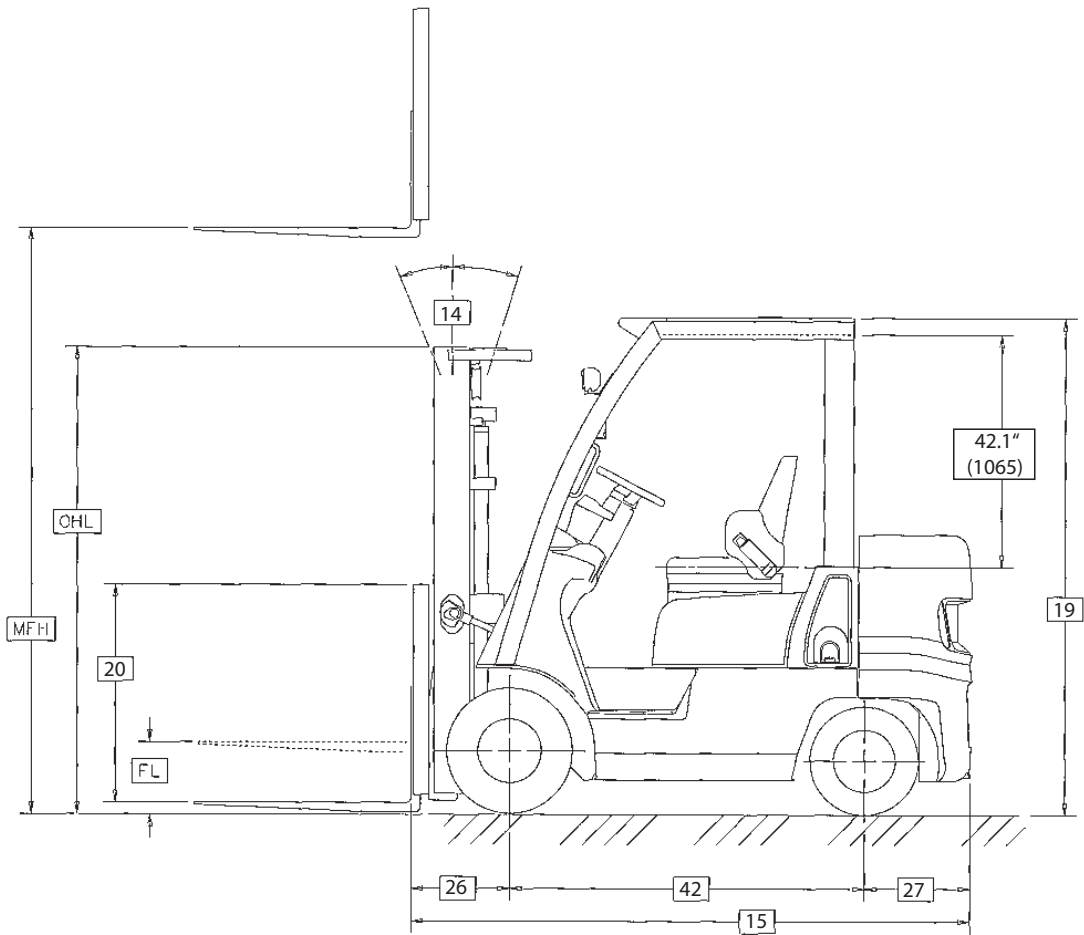
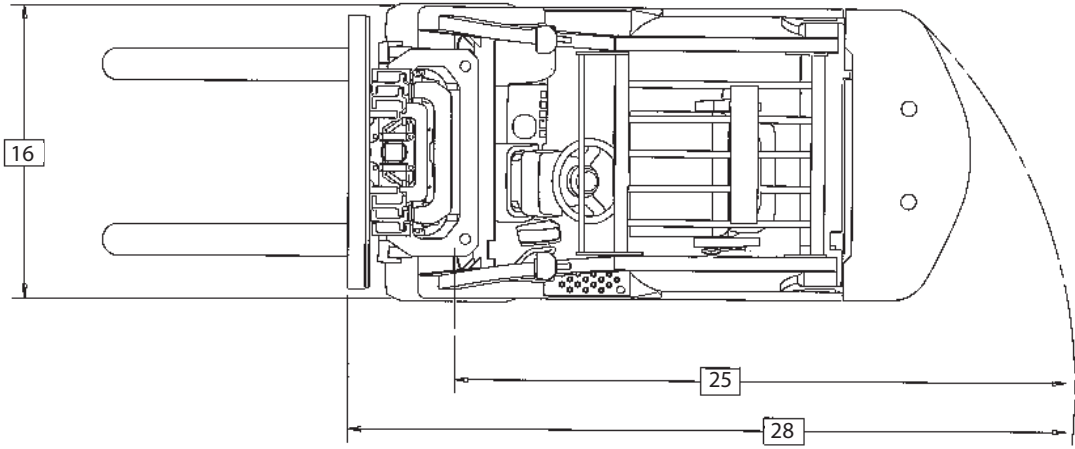

MAST SPECIFICATIONS & RATED CAPACITIES

Mast Name		Maximum Fork Height	Overall Height Lowered	Free Lift*	Tilt Angle Forward/Backward	Rated Capacity 24 in (600 mm) Load Center	
						AF30	AF35
		in (mm)	in (mm)	in (mm)	degrees	lb (kg)	lb (kg)
TWO STAGE (Wide view 2W)	2W270	106 (2700)	72.5 (1845)	6.2 (155)	5/5	3000 (1350)	3500 (1600)
	2W300	118 (3000)	78.4 (1995)	6.2 (155)	5/10	3000 (1350)	3500 (1600)
	2W330	130 (3300)	84.3 (2145)	6.2 (155)	5/10	3000 (1350)	3500 (1600)
	2W350	138 (3500)	89.6 (2275)	6.2 (155)	5/10	3000 (1350)	3500 (1600)
	2W370	146 (3700)	94.5 (2400)	6.2 (155)	5/10	3000 (1350)	3500 (1600)
	2W400	157 (4000)	102.0 (2595)	6.2 (155)	5/10	2950 (1350)	3400 (1550)
	2W450	177 (4500)	111.9 (2845)	6.2 (155)	5/5	2800 (1250)	3300 (1500)
	2W500	197 (5000)	121.7 (3095)	6.2 (155)	5/5	1300 (600)	3100 (1400)
TWO STAGE (Full free 2F)	2F270	105.5 (2700)	74 (1880)	47.4 (1200)	5/10	3000 (1350)	3500 (1600)
	2F300	117.5 (3000)	80 (2035)	53.4 (1355)	5/10	3000 (1350)	3500 (1600)
	2F330	129.5 (3300)	86 (2185)	59.4 (1505)	5/10	3000 (1350)	3500 (1600)
	2F350	137.5 (3500)	90 (2290)	63.4 (1610)	5/10	3000 (1350)	3400 (1550)
	2F370	145.5 (3700)	94 (2390)	67.4 (1710)	5/10	2900 (1300)	3350 (1500)
	2F400	157.5 (4000)	100 (2540)	73.4 (1860)	5/10	2850 (1300)	3300 (1500)
THREE STAGE (Full free 3F)	3F385	152 (3850)	72.5 (1845)	46.8 (1185)	5/5	2900 (1300)	3400 (1550)
	3F430	169 (4300)	78.4 (1995)	52.7 (1335)	5/5	2800 (1250)	3100 (1400)
	3F475	187 (4750)	84.3 (2145)	58.6 (1485)	5/5	2600 (1200)	2900 (1300)
	3F515	203 (5150)	89.6 (2275)	63.9 (1620)	5/5	2300 (1050)	2600 (1200)
	3F550	217 (5500)	94.5 (2400)	68.9 (1750)	5/5	2100 (950)	2400 (1100)
	3F600	236 (6000)	102.0 (2595)	76.3 (1935)	5/5	1800 (800)	2000 (900)
	3F650	256 (6500)	111.9 (2845)	86.2 (2185)	5/5	1700 (750)	1800 (800)
THREE STAGE OPTVIEW® (3V)	3V360	142 (3600)	72.5 (1845)	47.6 (1205)	5/5	2850 (1300)	3200 (1450)
	3V405	159 (4050)	78.4 (1995)	53.5 (1355)	5/5	2700 (1200)	3100 (1400)
	3V450	177 (4500)	84.3 (2145)	59.4 (1505)	5/5	2600 (1200)	2700 (1200)
	3V490	193 (4900)	89.6 (2275)	64.8 (1645)	5/5	2400 (1100)	2600 (1200)
	3V525	207 (5250)	94.5 (2400)	59.7 (1515)	5/5	2100 (950)	2300 (1050)
	3V575	226 (5750)	102.0 (2595)	77.2 (1960)	5/5	1800 (800)	2100 (950)
	3V633	249 (6330)	111.9 (2845)	87.0 (2205)	5/5	1600 (750)	1900 (850)
	QUAD (4Q)	4Q240	240.6 (6110)	84.9 (2160)	36.9 (936.7)	3/3	1700 (770)
4Q258		258.7 (6570)	91 (2310)	42.9 (1089.7)	3/3	1250 (570)	1150 (520)
4Q276		276.7 (7030)	97 (2465)	48.9 (1241.7)	3/3	900 (410)	800 (360)
4Q294		294.6 (7485)	102.9 (2615)	54.9 (1393.7)	3/3	600 (270)	500 (230)
4Q312		312.7 (7940)	109 (2770)	60.9 (1546.7)	3/3	350 (160)	250 (110)

Mast Name		Maximum Fork Height	Overall Height Lowered	Free Lift*	Tilt Angle Forward/Backward	Rated Capacity 24 in (600 mm) Load Center
						AF50
		in (mm)	in (mm)	in (mm)	degrees	lb (kg)
TWO STAGE (Wide view 2W)	2W270	106 (2700)	70.9 (1800)	4.2 (105)	5/10	5000 (2250)
	2W300	118 (3000)	76.9 (1955)	4.2 (105)	5/10	5000 (2250)
	2W330	130 (3300)	82.8 (2105)	4.2 (105)	5/10	5000 (2250)
	2W350	138 (3500)	88.1 (2240)	4.2 (105)	5/10	5000 (2250)
	2W370	146 (3700)	93.0 (2365)	4.2 (105)	5/10	5000 (2250)
	2W400	157 (4000)	100.5 (2555)	4.2 (105)	5/10	4950 (2250)
	2W450	177 (4500)	110.3 (2805)	4.2 (105)	5/5	4850 (2200)
	2W500	197 (5000)	120.2 (3055)	4.2 (105)	5/5	4700 (2150)
TWO STAGE (Full free 2F)	2F270	105.5 (2700)	74 (1880)	47.4 (1200)	5/10	5000 (2250)
	2F300	117.5 (3000)	80 (2035)	53.4 (1355)	5/10	5000 (2250)
	2F330	129.5 (3300)	86 (2185)	59.4 (1505)	5/10	5000 (2250)
	2F350	137.5 (3500)	90 (2290)	63.4 (1610)	5/10	5000 (2250)
	2F370	145.5 (3700)	94 (2390)	67.4 (1710)	5/10	5000 (2250)
	2F400	157.5 (4000)	100 (2540)	73.4 (1860)	5/10	4850 (2200)
THREE STAGE (Full free 3F)	3F385	152 (3850)	71.3 (1815)	46.9 (1190)	5/5	4950 (2250)
	3F430	169 (4300)	77.2 (1965)	52.8 (1340)	5/5	4800 (2200)
	3F475	187 (4750)	83.1 (2115)	58.7 (1490)	5/5	4350 (1950)
	3F515	203 (5150)	88.4 (2245)	64.0 (1625)	5/5	3900 (1750)
	3F550	217 (5500)	93.3 (2370)	68.9 (1750)	5/5	3550 (1600)
	3F600	236 (6000)	100.8 (2560)	76.4 (1940)	5/5	3100 (1400)
	3F650	256 (6500)	110.6 (2810)	86.2 (2185)	5/5	2700 (1200)
3F700	276 (7000)	120.5 (3065)	96.1 (2440)	5/5	2000 (900)	

*Without LBR

MAST SPECIFICATIONS & RATED CAPACITIES

Mast Name	Maximum Fork Height	Overall Height Lowered	Free Lift*	Tilt Angle Forward/Backward	Rated Capacity 24 in AF50	
	in (mm)	in (mm)	in (mm)	degrees	lb (kg)	
THREE STAGE OPTIVIEW® (3V)	3V360	142 (3600)	71.3 (1815)	47.8 (1210)	5/5	4950 (2250)
	3V405	159 (4050)	77.2 (1965)	53.7 (1360)	5/5	4800 (2200)
	3V450	177 (4500)	83.1 (2115)	59.6 (1510)	5/5	4350 (1950)
	3V490	193 (4900)	88.4 (2245)	64.9 (1645)	5/5	4250 (1950)
	3V525	207 (5250)	93.3 (2370)	69.8 (1770)	5/5	3550 (1600)
	3V575	226 (5750)	100.8 (2560)	77.3 (1960)	5/5	3100 (1400)
	3V633	249 (6330)	110.6 (2810)	87.2 (2210)	5/5	2400 (1100)
	3V688	271 (6880)	120.5 (3065)	97.0 (2460)	5/5	2000 (900)
QUAD (4Q)	4Q240	240.6 (6110)	82.8 (2100)	34.7 (881)	3/3	3850 (1750)
	4Q258	258.7 (6570)	88.8 (2255)	40.7 (1034)	3/3	3050 (1390)
	4Q276	276.7 (7030)	94.8 (2405)	46.7 (1186)	3/3	2350 (1070)
	4Q294	294.6 (7485)	100.7 (2560)	52.7 (1338)	3/3	1800 (820)
	4Q312	312.7 (7940)	106.8 (2710)	58.7 (1491)	3/3	1400 (640)

*Without LBR

STANDARD EQUIPMENT

VEHICLE MANAGEMENT

- Vehicle Control Module (VCM)
- Interactive LCD meter panel
 - Hour meter, clock, calendar
 - Programmable service reminders
 - Warning lights (oil pressure, transmission fluid, low coolant)
 - Speedometer & F/N/R transmission indicator
 - LPMax low fuel warning (LP/Dual Fuel)
 - Fuel gauge

POWERTRAIN / FUEL SYSTEM

- GK21 electronic fuel injected industrial engine
- Electronic engine control system
- Three-way catalytic converter
- Swing-out LP bracket
- Maximum travel speed control

BRAKE

- Parking brake with warning buzzer
- Parking brake with transmission interlock

MAST / HYDRAULIC SYSTEM

- Seat-actuated auto-mast lock system
- High visibility carriage
- Three-spool control valve with pressure relief

OPERATOR CONVENIENCES

- Full suspension seat with weight & lumbar adjustment
- Overhead guard-mounted LED headlights
- Adjustable tilt steering wheel with memory lever

PROTECTION / SECURITY

- Operator Presence System
 - Auto-mast lock
 - Return-to-neutral
 - Parking brake with warning buzzer
- Horn
- Back-up alarm
- Cushioned stability control
- Five-piece overhead guard

OPTIONAL EQUIPMENT

- SmoothShift System
- Starter interlock (low LP)
- Travel speed control (high/low speed selector)²
- Controlled acceleration (power/economy selector)²
- Radiator screen
- Open core radiator
- Air intake pre-cleaner
- Diffusion exhaust muffler
- Swing-down LP bracket¹
- OptiView three-stage mast
- Separate lift & tilt control levers (no charge)
- Electronic fingertip hydraulic controls (seat-mounted)¹
- Automatic fork leveling¹
- Fork Positioner (Hang-On)
- Blue LED Pedestrian Awareness Light
- Sideshifters (integral or hang-on)
- Tilt cylinder boots & covers
- Bottler's tilt
- Rearview mirrors (glass or impact resistant)
- Rear LED combination light package (turn, stop, back-up)
- Reverse-activated rear LED drive light
- Secure rear grip with horn button¹
- Seatbelt interlocks
- UL safety rating
- Self-adjusting back-up alarm
- Fire extinguisher
- Strobe lights
- Rotating beacons
- Steering wheel with spinner knob

¹ Available on select models. Contact your UniCarriers Forklift dealer for details.

² Features can be combined. Available with rocker or key switch. Select 'Economy setting always on' for greatest fuel savings.

ERGONOMICS & COMFORT

The Nomad Series offers a variety of operator conveniences for greater productivity including standard full suspension seat for enhanced shock absorption. Seat includes lumbar support adjustment, weight-adjustment plus operator restraint armrests. Non-cinching seat belt provides greater range of movement. Adjustable tilt steering column includes memory lever. Operator Presence System has Return-to-Neutral and Auto-Mast Lock (automatically locking mast lift and tilt when the operator leaves the seat). Audible and visual warnings notify operator if seat belt is not engaged while traveling, or if parking brake is not applied before exiting truck. A standard parking brake transmission interlock keeps the forklift in neutral and prevents the operator from driving while the parking brake is engaged to protect the brakes and transmission and reduce premature brake wear.

Compact front cowl offers generous leg and foot room. Low profile design provides ample head clearance. Optional secure assist grip is mounted to the rear, right pillar, keeping the operator's hand safely inside the compartment during reverse travel. Can be purchased with an optional swivel seat* that pivots 15° to left and right. [Reduces headroom by 1" (25mm)].

Hydrostatic power steering system reduces operator effort for easier maneuvering and less fatigue. Automotive-style levers simplify repetitive actions for greater operator focus. Exclusive single hydraulic control lever design combines lift and tilt operations into one fluid motion for greater productivity. Separate control levers available at no charge. Optional auto-tilt leveling system assists operator during mast/fork positioning. Optional fingertip control levers with adjustable armrest provide enhanced comfort*.

EFFICIENCY & CONTROL

Welded metal assist grip combined with replaceable metal traction plate bolted to a wide, low entry step, provide secure footing and grip for this often-repeated task. Small steering wheel delivers control and provides operator with clear view of meter panel with visibility to warnings and indicators.

The Nomad Series may be programmed with Personal Identification Number (PIN) codes to restrict unauthorized truck usage for greater fleet control.

Control of maximum travel speed is adjustable through the meter panel by a trained service technician. Optional Power/Economy controlled acceleration mode adjusts throttle sensitivity to increase fuel efficiency, extend drivetrain life and reduce excessive tire wear. An optional swing-down LP tank holder* swings out 90°, then pulls down to a manageable height, requiring less force for simplified change out.

Exclusive maintenance-free cushioned stability control with rubber dampers located between rear axle and body enhance lateral stability under normal driving conditions.

* Available on select models

LEGENDARY GK-SERIES INDUSTRIAL ENGINE

All Nomad models are powered by our GK21 (2.1 ℓ) electronically controlled fuel injected industrial engine which includes a bottom-bypass design with thermostat to eliminate hot spots during start-up and prolong engine life. Designed and tested specifically for industrial applications, GK21 engines deliver high power and torque (in the low rpm range) more efficiently. An engine protection and warning system is standard, reducing speed in case of excessive heat generation or oil pressure loss. System includes three main components [Engine Control Module (ECM), Vehicle Control Module (VCM), and Multi-function LCD]. The ECM analyzes engine performance parameters and optimizes engine operation for enhanced productivity and lower fuel consumption. The ECM responds to sensor input by controlling basic engine-related functions (proper air/fuel ratio, torque and speed) based on application requirements. The VCM monitors sensors for changing truck conditions, alerting operator through warning indicators located on the meter panel. Communication among these components occurs through a Controller Area Network (CAN) system.

LOW EMISSIONS

UniCarriers Forklift's global commitment to preserving and protecting the environment is evident in our low emission engines. GK21 engines include a three-way catalytic muffler and an automotive-type, closed-loop design, providing cleaner exhaust emissions through lower CO (Carbon Monoxide) and lower HC+NOx (Greenhouse Gases) levels. Operators will experience low noise levels during idle and while driving at maximum travel speeds.

LOWER OPERATING COSTS

No tools are required to remove the one-piece diamond tread floorboard, promoting fast, simple access to hydraulic and other serviceable components. Detachable side panels and a wide-open hood provide a roomy area for service technicians. Unique five-piece overhead guard simplifies replacement of individual components if necessary, saving time and money. An opening in the dash panel allows for fast brake fluid level checks. Multi-function LCD panel with on-board diagnostics reduces service time. Programmable service reminder settings keep periodic/planned maintenance on schedule.



LogisnextAmericas.com/UniCarriers

SS-NOMAD 07-2023 Printed in U.S.A.

© 2023 Mitsubishi Logisnext Americas Inc. UniCarriers®, Nomad®, and OptiView® are a registered trademark of Mitsubishi Logisnext Co., Ltd. Mitsubishi Logisnext Americas, Inc. reserves the right to make product changes relating to colors, equipment, specifications or available options without notice. For more information, contact your UniCarriers Forklift representative.

